

---

# *Request for Proposal FY 2023 Pavement Restoration Program*

FOR



## Warren Escovy

City Administrator

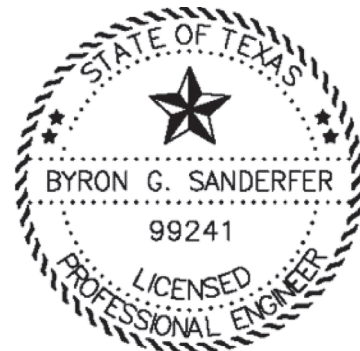

12/01/22

Prepared by:

A handwritten signature in blue ink that reads "Byron Sanderfer".



## ARDURRA

COLLABORATE. INNOVATE. CREATE.

TBPE FIRM NO. F-10053

8918 Tesoro Drive, Suite 401

San Antonio, Texas 78217

Ph: (210) 822-2232

Fax: (210) 822-4032

## Request for Proposal

### Instructions to Bidders

The City of Blanco will receive proposals for the FY 2023 Pavement Restoration Program until 2:00 pm on Friday, December 16, 2022, to the City Secretary at 300 Pecan St, Blanco, Tx 78606 or by email to [Jteafatiller@ardurra.com](mailto:Jteafatiller@ardurra.com).

### Project Duration

This task order contract shall be terminated three hundred and sixty-five (365) calendar days after the issuance of the first task order. The construction time (in calendar days) for each individual task order will be negotiated between the City Engineer and the Contractor. The Contractor will be expected to begin construction for each individual task order within 7 calendar days of the notice to proceed.

### Project Scope

The project entails spot pavement repair and edge repair in various locations throughout the City of Blanco. The project scope includes approximately 3,125 square yards of pavement repair which will be split into one or more tasks orders. Pavement repair and edge repair areas will be identified and located in the field by the City Engineer. Pavement repair and edge repair shall be performed in accordance with the pavement repair details and technical specifications included within this request for proposal and technical specifications.

**Quantities included in this contract, as well as the entire bid amount are not guaranteed. Unit prices established shall remain valid throughout the duration of the contract. The City of Blanco's budget for the proposed work is approximately \$250,000 which is not guaranteed.**

### Project Location

Project locations are not provided in this contract and could be spread throughout the city. Each project will be issued as a separate Task Order and quantities will be provided to the Contractor.

### Important Notes

No direct payment shall be made for mobilization, insurance, bonding, preparing right-of-way, traffic control, removing and hauling off material, and all other subsidiary construction methods. The Contractor shall include these costs as part of the various bid items.

### Traffic Control

The traffic control plan shall be in accordance with TxDOT Barricades and Construction standards for each task order.

### Final Payment and Task Order Closeout

When all work on an issued Task Order is complete in full, and the Contractor has received from the City both a Notice of Substantial Completion and Final Completion of Work, Contractor shall submit the final payment request and notate that the applicable payment request is Final. The Task Order will then be closed out by City and Contractor. Upon completion of payment request cycle and receipt of final payment by Contractor, Contractor agrees that all balances associated with Task Order have been paid in full. Final payment by the City shall constitute Final Completion of Work.

**The contractor shall utilize the details and Specifications that are included in this request for proposal.**

---

## CITY OF BLANCO

---

Project Name: FY 2023 Pavement Restoration Program –Date Issued: December 2022

The estimated construction budget for this contract is \$250,000

### Bid Proposal Form

---

Legal Name of Company (Print)

#### I. BASE BID

ITEM	QTY	DESCRIPTION	UNIT	UNIT PRICE	TOTAL
341.5.1	3125	BASE REPAIR (HMA TY B)	SY		
341.5.2	500	EDGE REPAIR (HMA TY B)	LF		

Total Amount of Base Bid (Insert Amount in Words and Numbers):

---

Person Authorized to Sign Bid/Contract (Print)

---

Title of Person Signing

---

Tax ID No.

---

Address

---

Fax No.

---

City, State, and Zip Code

---

Telephone No.

---

E-Mail Address

---

Name of the Proposed Project Manager: \_\_\_\_\_

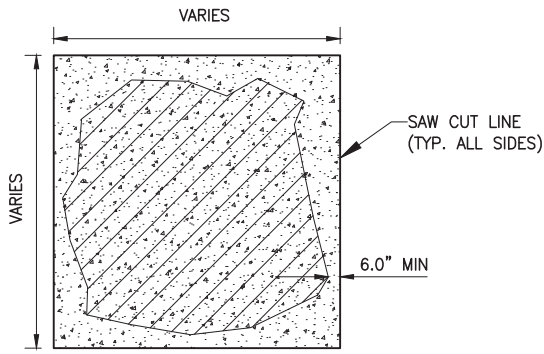

 - AREA OF FAILED OR DISTRESSED PAVEMENT

 - AREA PAVEMENT REPAIR

NOTES:

1. BASE REPAIR AND EDGE REPAIR SECTIONS WILL BE MARKED AND IDENTIFIED IN THE FIELD BY THE ENGINEER WITH THE CONTRACTOR.
2. THE CONTRACTOR SHALL ESTABLISH CLEAN CUT EDGES ALONG WITH FLUSH FINISH TRANSITIONS FOR A SMOOTH DRIVING SURFACE.
3. GRADING, EXCAVATING, AND REMOVAL OF EXCESS MATERIAL WILL NOT BE PAID FOR SEPARATELY BUT WILL BE CONSIDERED SUBSIDIARY TO THE VARIOUS BID ITEMS.
4. THE CONTRACTOR IS RESPONSIBLE FOR SEQUENCING WORK IN A REASONABLE MANNER AS TO NOT IMPEDE TRAFFIC OR BLOCK DRIVEWAY ENTRANCES. TRAFFIC CONTROL AND BARRICADES WILL NOT BE PAID FOR SEPARATELY.
5. TACK COAT SHALL BE APPLIED AT 0.1 GAL PER SQUARE YARD AND IN ACCORDANCE TO TXDOT SPECIFICATION 300. NO SEPERATE PAY ITEM (NSPI).

**1 PAVEMENT REPAIR PLAN VIEW**  
NOT TO SCALE

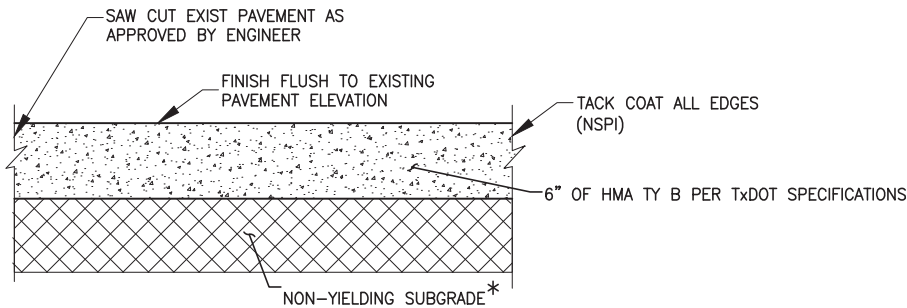

\* IF SOFT SPOTS ARE ENCOUNTERED AT A 6" DEPTH, THE CONTRACTOR SHALL TREAT THE EXISTING SUBGRADE WITH SACKS OF CEMENT, OR EXCAVATE FURTHER TO ACHIEVE A NON-YIELDING SUBGRADE. THIS SHALL BE CONSIDERED SUBSIDIARY TO THE PAVEMENT REPAIR PAY ITEM.

**2 PAVEMENT REPAIR SECTION**  
NOT TO SCALE

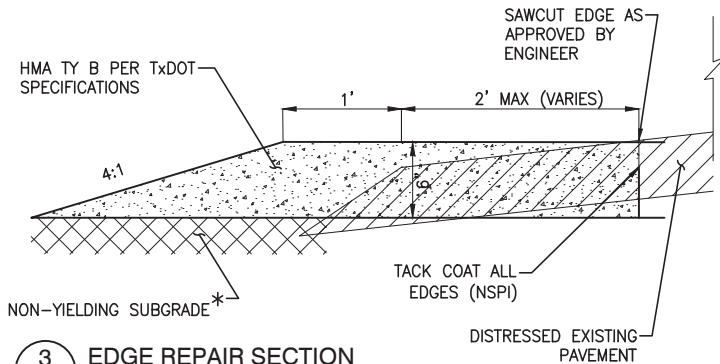

**3 EDGE REPAIR SECTION**  
NOT TO SCALE

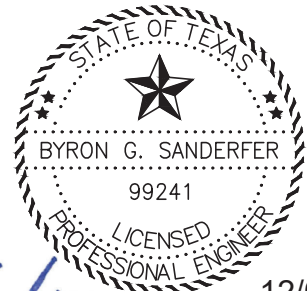

*Byron Sanderfer*

12/01/22

S:\Projects\Blanco\220001\_Engineering\_Services\000\20-Drawings\Plans\PAVEMENT\_REPAIR.dwg Thursday, December 01, 2022, 10:44am



8918 Tesoro Dr., Suite 401  
San Antonio, Texas 78217  
Phone: (210) 822-2232  
www.Ardurra.com  
Engineering License #E-10053  
Ardurra Group, Inc.  
Surveying Firm 10126502

CITY OF BLANCO  
FY 2023 PAVEMENT RESTORATION PROGRAM  
**PAVEMENT REPAIR DETAILS**



# Item 341

## Dense-Graded Hot-Mix Asphalt



### 1. DESCRIPTION

Construct a hot-mix asphalt (HMA) pavement layer composed of a compacted, dense-graded mixture of aggregate and asphalt binder mixed hot in a mixing plant. Payment adjustments will apply to HMA placed under this specification unless the HMA is deemed exempt in accordance with Section 341.4.9.4., "Exempt Production."

### 2. MATERIALS

Furnish uncontaminated materials of uniform quality that meet the requirements of the plans and specifications.

Notify the Engineer of all material sources and before changing any material source or formulation. The Engineer will verify that the specification requirements are met when the Contractor makes a source or formulation change, and may require a new laboratory mixture design, trial batch, or both. The Engineer may sample and test project materials at any time during the project to verify specification compliance in accordance with Item 6, "Control of Materials."

- 2.1. **Aggregate.** Furnish aggregates from sources that conform to the requirements shown in Table 1 and as specified in this Section. Aggregate requirements in this Section, including those shown in Table 1, may be modified or eliminated when shown on the plans. Additional aggregate requirements may be specified when shown on the plans. Provide aggregate stockpiles that meet the definitions in this Section for coarse, intermediate, or fine aggregate. Aggregate from reclaimed asphalt pavement (RAP) is not required to meet Table 1 requirements unless otherwise shown on the plans. Supply aggregates that meet the definitions in [Tex-100-E](#) for crushed gravel or crushed stone. The Engineer will designate the plant or the quarry as the sampling location. Provide samples from materials produced for the project. The Engineer will establish the Surface Aggregate Classification (SAC) and perform Los Angeles abrasion, magnesium sulfate soundness, and Micro-Deval tests. Perform all other aggregate quality tests listed in Table 1. Document all test results on the mixture design report. The Engineer may perform tests on independent or split samples to verify Contractor test results. Stockpile aggregates for each source and type separately. Determine aggregate gradations for mixture design and production testing based on the washed sieve analysis given in [Tex-200-F](#), Part II.

- 2.1.1. **Coarse Aggregate.** Coarse aggregate stockpiles must have no more than 20% material passing the No. 8 sieve. Aggregates from sources listed in the Department's *Bituminous Rated Source Quality Catalog* (BRSQC) are preapproved for use. Use only the rated values for hot-mix listed in the BRSQC. Rated values for surface treatment (ST) do not apply to coarse aggregate sources used in hot-mix asphalt.

For sources not listed on the Department's BRSQC:

- build an individual stockpile for each material;
- request the Department test the stockpile for specification compliance; and
- once approved, do not add material to the stockpile unless otherwise approved.

Provide aggregate from non-listed sources only when tested by the Engineer and approved before use. Allow 30 calendar days for the Engineer to sample, test, and report results for non-listed sources.

Provide coarse aggregate with at least the minimum SAC shown on the plans. SAC requirements only apply to aggregates used on the surface of travel lanes. SAC requirements apply to aggregates used on surfaces

other than travel lanes when shown on the plans. The SAC for sources on the Department's *Aggregate Quality Monitoring Program (AQMP)* ([Tex-499-A](#)) is listed in the BRSQC.

- 2.1.1.1. **Blending Class A and Class B Aggregates.** Class B aggregate meeting all other requirements in Table 1 may be blended with a Class A aggregate to meet requirements for Class A materials. Ensure that at least 50% by weight, or volume if required, of the material retained on the No. 4 sieve comes from the Class A aggregate source when blending Class A and B aggregates to meet a Class A requirement. Blend by volume if the bulk specific gravities of the Class A and B aggregates differ by more than 0.300. Coarse aggregate from RAP and Recycled Asphalt Shingles (RAS) will be considered as Class B aggregate for blending purposes.

The Engineer may perform tests at any time during production, when the Contractor blends Class A and B aggregates to meet a Class A requirement, to ensure that at least 50% by weight, or volume if required, of the material retained on the No. 4 sieve comes from the Class A aggregate source. The Engineer will use the Department's mix design template, when electing to verify conformance, to calculate the percent of Class A aggregate retained on the No. 4 sieve by inputting the bin percentages shown from readouts in the control room at the time of production and stockpile gradations measured at the time of production. The Engineer may determine the gradations based on either washed or dry sieve analysis from samples obtained from individual aggregate cold feed bins or aggregate stockpiles. The Engineer may perform spot checks using the gradations supplied by the Contractor on the mixture design report as an input for the template; however, a failing spot check will require confirmation with a stockpile gradation determined by the Engineer.

- 2.1.1.2. **Micro-Deval Abrasion.** The Engineer will perform a minimum of one Micro-Deval abrasion test in accordance with [Tex-461-A](#) for each coarse aggregate source used in the mixture design that has a Rated Source Soundness Magnesium (RSSM) loss value greater than 15 as listed in the BRSQC. The Engineer will perform testing before the start of production and may perform additional testing at any time during production. The Engineer may obtain the coarse aggregate samples from each coarse aggregate source or may require the Contractor to obtain the samples. The Engineer may waive all Micro-Deval testing based on a satisfactory test history of the same aggregate source.

The Engineer will estimate the magnesium sulfate soundness loss for each coarse aggregate source, when tested, using the following formula:

$$Mg_{est.} = (RSSM)(MD_{act.}/RSMD)$$

where:

$Mg_{est.}$  = magnesium sulfate soundness loss

$MD_{act.}$  = actual Micro-Deval percent loss

$RSMD$  = Rated Source Micro-Deval

When the estimated magnesium sulfate soundness loss is greater than the maximum magnesium sulfate soundness loss specified, the coarse aggregate source will not be allowed for use unless otherwise approved. The Engineer will consult the Geotechnical, Soils, and Aggregates Branch of the Construction Division, and additional testing may be required before granting approval.

- 2.1.2. **Intermediate Aggregate.** Aggregates not meeting the definition of coarse or fine aggregate will be defined as intermediate aggregate. Supply intermediate aggregates, when used that are free from organic impurities. The Engineer may test the intermediate aggregate in accordance with [Tex-408-A](#) to verify the material is free from organic impurities. Supply intermediate aggregate from coarse aggregate sources, when used that meet the requirements shown in Table 1 unless otherwise approved.

Test the stockpile if 10% or more of the stockpile is retained on the No. 4 sieve, and verify that it meets the requirements in Table 1 for crushed face count ([Tex-460-A](#)) and flat and elongated particles ([Tex-280-F](#)).

- 2.1.3. **Fine Aggregate.** Fine aggregates consist of manufactured sands, screenings, and field sands. Fine aggregate stockpiles must meet the gradation requirements in Table 2. Supply fine aggregates that are free from organic impurities. The Engineer may test the fine aggregate in accordance with [Tex-408-A](#) to verify the

material is free from organic impurities. No more than 15% of the total aggregate may be field sand or other uncrushed fine aggregate. Use fine aggregate, with the exception of field sand, from coarse aggregate sources that meet the requirements shown in Table 1 unless otherwise approved.

Test the stockpile if 10% or more of the stockpile is retained on the No. 4 sieve and verify that it meets the requirements in Table 1 for crushed face count ([Tex-460-A](#)) and flat and elongated particles ([Tex-280-F](#)).

**Table 1**  
**Aggregate Quality Requirements**

Property	Test Method	Requirement
<b>Coarse Aggregate</b>		
SAC	<a href="#">Tex-499-A</a> (AQMP)	As shown on the plans
Deleterious material, %, Max	<a href="#">Tex-217-F</a> , Part I	1.5
Decantation, %, Max	<a href="#">Tex-217-F</a> , Part II	1.5
Micro-Deval abrasion, %	<a href="#">Tex-461-A</a>	Note 1
Los Angeles abrasion, %, Max	<a href="#">Tex-410-A</a>	40
Magnesium sulfate soundness, 5 cycles, %, Max	<a href="#">Tex-411-A</a>	30
Crushed face count, <sup>2</sup> %, Min	<a href="#">Tex-460-A</a> , Part I	85
Flat and elongated particles @ 5:1, %, Max	<a href="#">Tex-280-F</a>	10
<b>Fine Aggregate</b>		
Linear shrinkage, %, Max	<a href="#">Tex-107-E</a>	3
<b>Combined Aggregate<sup>3</sup></b>		
Sand equivalent, %, Min	<a href="#">Tex-203-F</a>	45

1. Used to estimate the magnesium sulfate soundness loss in accordance with Section 341.2.1.1.2., "Micro-Deval Abrasion."
2. Only applies to crushed gravel.
3. Aggregates, without mineral filler, RAP, RAS, or additives, combined as used in the job-mix formula (JMF).

**Table 2**  
**Gradation Requirements for Fine Aggregate**

Sieve Size	% Passing by Weight or Volume
3/8"	100
#8	70–100
#200	0–30

- 2.2. **Mineral Filler.** Mineral filler consists of finely divided mineral matter such as agricultural lime, crusher fines, hydrated lime, or fly ash. Mineral filler is allowed unless otherwise shown on the plans. Use no more than 2% hydrated lime or fly ash unless otherwise shown on the plans. Use no more than 1% hydrated lime if a substitute binder is used unless otherwise shown on the plans or allowed. Test all mineral fillers except hydrated lime and fly ash in accordance with [Tex-107-E](#) to ensure specification compliance. The plans may require or disallow specific mineral fillers. Provide mineral filler, when used, that:

- is sufficiently dry, free-flowing, and free from clumps and foreign matter as determined by the Engineer;
- does not exceed 3% linear shrinkage when tested in accordance with [Tex-107-E](#); and
- meets the gradation requirements in Table 3.

**Table 3**  
**Gradation Requirements for Mineral Filler**

Sieve Size	% Passing by Weight or Volume
#8	100
#200	55–100

- 2.3. **Baghouse Fines.** Fines collected by the baghouse or other dust-collecting equipment may be reintroduced into the mixing drum.
- 2.4. **Asphalt Binder.** Furnish the type and grade of performance-graded (PG) asphalt specified on the plans.
- 2.5. **Tack Coat.** Furnish CSS-1H, SS-1H, or a PG binder with a minimum high-temperature grade of PG 58 for tack coat binder in accordance with Item 300, "Asphalts, Oils, and Emulsions." Specialized or preferred tack

coat materials may be allowed or required when shown on the plans. Do not dilute emulsified asphalts at the terminal, in the field, or at any other location before use.

The Engineer will obtain at least one sample of the tack coat binder per project in accordance with [Tex-500-C](#), Part III, and test it to verify compliance with Item 300, "Asphalts, Oils, and Emulsions." The Engineer will obtain the sample from the asphalt distributor immediately before use.

- 2.6. **Additives.** Use the type and rate of additive specified when shown on the plans. Additives that facilitate mixing, compaction, or improve the quality of the mixture are allowed when approved. Provide the Engineer with documentation such as the bill of lading showing the quantity of additives used in the project unless otherwise directed.
- 2.6.1. **Lime and Liquid Antistripping Agent.** When lime or a liquid antistripping agent is used, add in accordance with Item 301, "Asphalt Antistripping Agents." Do not add lime directly into the mixing drum of any plant where lime is removed through the exhaust stream unless the plant has a baghouse or dust collection system that reintroduces the lime into the drum.
- 2.6.2. **Warm Mix Asphalt (WMA).** Warm Mix Asphalt (WMA) is defined as HMA that is produced within a target temperature discharge range of 215°F and 275°F using approved WMA additives or processes from the Department's MPL.

WMA is allowed for use on all projects and is required when shown on the plans. When WMA is required, the maximum placement or target discharge temperature for WMA will be set at a value below 275°F.

Department-approved WMA additives or processes may be used to facilitate mixing and compaction of HMA produced at target discharge temperatures above 275°F; however, such mixtures will not be defined as WMA.

- 2.7. **Recycled Materials.** Use of RAP and RAS is permitted unless otherwise shown on the plans. Do not exceed the maximum allowable percentages of RAP and RAS shown in Table 4. The allowable percentages shown in Table 4 may be decreased or increased when shown on the plans. Determine asphalt binder content and gradation of the RAP and RAS stockpiles for mixture design purposes in accordance with [Tex-236-F](#). The Engineer may verify the asphalt binder content of the stockpiles at any time during production. Perform other tests on RAP and RAS when shown on the plans. Asphalt binder from RAP and RAS is designated as recycled asphalt binder. Calculate and ensure that the ratio of the recycled asphalt binder to total binder does not exceed the percentages shown in Table 5 during mixture design and HMA production when RAP or RAS is used. Use a separate cold feed bin for each stockpile of RAP and RAS during HMA production.

Surface, intermediate, and base mixes referenced in Tables 4 and 5 are defined as follows:

- **Surface.** The final HMA lift placed at or near the top of the pavement structure;
- **Intermediate.** Mixtures placed below an HMA surface mix and less than or equal to 8.0 in. from the riding surface; and
- **Base.** Mixtures placed greater than 8.0 in. from the riding surface.

- 2.7.1. **RAP.** RAP is salvaged, milled, pulverized, broken, or crushed asphalt pavement. Crush or break RAP so that 100% of the particles pass the 2 in. sieve. Fractionated RAP is defined as 2 or more RAP stockpiles, divided into coarse and fine fractions.

Use of Contractor-owned RAP including HMA plant waste is permitted unless otherwise shown on the plans. Department-owned RAP stockpiles are available for the Contractor's use when the stockpile locations are shown on the plans. If Department-owned RAP is available for the Contractor's use, the Contractor may use Contractor-owned fractionated RAP and replace it with an equal quantity of Department-owned RAP. This allowance does not apply to a Contractor using unfractionated RAP. Department-owned RAP generated through required work on the Contract is available for the Contractor's use when shown on the plans. Perform any necessary tests to ensure Contractor- or Department-owned RAP is appropriate for use. The Department will not perform any tests or assume any liability for the quality of the Department-owned RAP



unless otherwise shown on the plans. The Contractor will retain ownership of RAP generated on the project when shown on the plans.

The coarse RAP stockpile will contain only material retained by processing over a 3/8-in. or 1/2-in. screen unless otherwise approved. The fine RAP stockpile will contain only material passing the 3/8-in. or 1/2-in. screen unless otherwise approved. The Engineer may allow the Contractor to use an alternate to the 3/8-in. or 1/2-in. screen to fractionate the RAP. The maximum percentages of fractionated RAP may be comprised of coarse or fine fractionated RAP or the combination of both coarse and fine fractionated RAP.

Do not use Department- or Contractor-owned RAP contaminated with dirt or other objectionable materials. Do not use Department- or Contractor-owned RAP if the decantation value exceeds 5% and the plasticity index is greater than 8. Test the stockpiled RAP for decantation in accordance with [Tex-406-A](#), Part I. Determine the plasticity index in accordance with [Tex-106-E](#) if the decantation value exceeds 5%. The decantation and plasticity index requirements do not apply to RAP samples with asphalt removed by extraction or ignition.

Do not intermingle Contractor-owned RAP stockpiles with Department-owned RAP stockpiles. Remove unused Contractor-owned RAP material from the project site upon completion of the project. Return unused Department-owned RAP to the designated stockpile location.

**Table 4**  
**Maximum Allowable Amounts of RAP<sup>1</sup>**

Maximum Allowable Fractionated RAP <sup>2</sup> (%)			Maximum Allowable Unfractionated RAP <sup>3</sup> (%)		
Surface	Intermediate	Base	Surface	Intermediate	Base
20.0	30.0	40.0	10.0	10.0	10.0

1. Must also meet the recycled binder to total binder ratio shown in Table 5.
2. Up to 5% RAS may be used separately or as a replacement for fractionated RAP.
3. Unfractionated RAP may not be combined with fractionated RAP or RAS.

#### 2.7.2.

**RAS.** Use of post-manufactured RAS or post-consumer RAS (tear-offs) is permitted unless otherwise shown on the plans. Up to 5% RAS may be used separately or as a replacement for fractionated RAP in accordance with Table 4 and Table 5. RAS is defined as processed asphalt shingle material from manufacturing of asphalt roofing shingles or from re-roofing residential structures. Post-manufactured RAS is processed manufacturer's shingle scrap by-product. Post-consumer RAS is processed shingle scrap removed from residential structures. Comply with all regulatory requirements stipulated for RAS by the TCEQ. RAS may be used separately or in conjunction with RAP.

Process the RAS by ambient grinding or granulating such that 100% of the particles pass the 3/8 in. sieve when tested in accordance with [Tex-200-F](#), Part I. Perform a sieve analysis on processed RAS material before extraction (or ignition) of the asphalt binder.

Add sand meeting the requirements of Table 1 and Table 2 or fine RAP to RAS stockpiles if needed to keep the processed material workable. Any stockpile that contains RAS will be considered a RAS stockpile and be limited to no more than 5.0% of the HMA mixture in accordance with Table 4.

Certify compliance of the RAS with [DMS-11000](#), "Evaluating and Using Nonhazardous Recyclable Materials Guidelines." Treat RAS as an established nonhazardous recyclable material if it has not come into contact with any hazardous materials. Use RAS from shingle sources on the Department's MPL. Remove substantially all materials before use that are not part of the shingle, such as wood, paper, metal, plastic, and felt paper. Determine the deleterious content of RAS material for mixture design purposes in accordance with [Tex-217-F](#), Part III. Do not use RAS if deleterious materials are more than 0.5% of the stockpiled RAS unless otherwise approved. Submit a sample for approval before submitting the mixture design. The Department will perform the testing for deleterious material of RAS to determine specification compliance.

2.8.

**Substitute Binders.** Unless otherwise shown on the plans, the Contractor may use a substitute PG binder listed in Table 5 instead of the PG binder originally specified, if the substitute PG binder and mixture made with the substitute PG binder meet the following:

- the substitute binder meets the specification requirements for the substitute binder grade in accordance with Section 300.2.10., “Performance-Graded Binders;” and
- the mixture has less than 10.0 mm of rutting on the Hamburg Wheel test ([Tex-242-F](#)) after the number of passes required for the originally specified binder. Use of substitute PG binders may only be allowed at the discretion of the Engineer if the Hamburg Wheel test results are between 10.0 mm and 12.5 mm.

**Table 5**  
**Allowable Substitute PG Binders and Maximum Recycled Binder Ratios**

Originally Specified PG Binder	Allowable Substitute PG Binder	Maximum Ratio of Recycled Binder <sup>1</sup> to Total Binder (%)		
		Surface	Intermediate	Base
<b>HMA</b>				
76-22 <sup>2</sup>	70-22 or 64-22	20.0	20.0	20.0
	70-28 or 64-28	30.0	35.0	40.0
70-22 <sup>2</sup>	64-22	20.0	20.0	20.0
	64-28 or 58-28	30.0	35.0	40.0
64-22 <sup>2</sup>	58-28	30.0	35.0	40.0
76-28 <sup>2</sup>	70-28 or 64-28	20.0	20.0	20.0
	64-34	30.0	35.0	40.0
70-28 <sup>2</sup>	64-28 or 58-28	20.0	20.0	20.0
	64-34 or 58-34	30.0	35.0	40.0
64-28 <sup>2</sup>	58-28	20.0	20.0	20.0
	58-34	30.0	35.0	40.0
<b>WMA<sup>3</sup></b>				
76-22 <sup>2</sup>	70-22 or 64-22	30.0	35.0	40.0
70-22 <sup>2</sup>	64-22 or 58-28	30.0	35.0	40.0
64-22 <sup>4</sup>	58-28	30.0	35.0	40.0
76-28 <sup>2</sup>	70-28 or 64-28	30.0	35.0	40.0
70-28 <sup>2</sup>	64-28 or 58-28	30.0	35.0	40.0
64-28 <sup>4</sup>	58-28	30.0	35.0	40.0

1. Combined recycled binder from RAP and RAS.
2. Use no more than 20.0% recycled binder when using this originally specified PG binder.
3. WMA as defined in Section 341.2.6.2., “Warm Mix Asphalt (WMA).”
4. When used with WMA, this originally specified PG binder is allowed for use at the maximum recycled binder ratios shown in this table.

---

### 3. EQUIPMENT

Provide required or necessary equipment in accordance with Item 320, “Equipment for Asphalt Concrete Pavement.”

---

### 4. CONSTRUCTION

Produce, haul, place, and compact the specified paving mixture. In addition to tests required by the specification, Contractors may perform other QC tests as deemed necessary. At any time during the project, the Engineer may perform production and placement tests as deemed necessary in accordance with Item 5, “Control of the Work.” Schedule and participate in a mandatory pre-paving meeting with the Engineer on or before the first day of paving unless otherwise shown on the plans.

- 4.1. **Certification.** Personnel certified by the Department-approved hot-mix asphalt certification program must conduct all mixture designs, sampling, and testing in accordance with Table 6. Supply the Engineer with a list of certified personnel and copies of their current certificates before beginning production and when personnel changes are made. Provide a mixture design developed and signed by a Level 2 certified specialist. Provide Level 1A certified specialists at the plant during production operations. Provide Level 1B certified specialists to conduct placement tests.

**Table 6**  
**Test Methods, Test Responsibility, and Minimum Certification Levels**

Test Description	Test Method	Contractor	Engineer	Level <sup>1</sup>
<b>1. Aggregate and Recycled Material Testing</b>				
Sampling	<a href="#">Tex-221-F</a>	✓	✓	1A
Dry sieve	<a href="#">Tex-200-F, Part I</a>	✓	✓	1A
Washed sieve	<a href="#">Tex-200-F, Part II</a>	✓	✓	1A
Deleterious material	<a href="#">Tex-217-F, Parts I &amp; III</a>	✓	✓	1A
Decantation	<a href="#">Tex-217-F, Part II</a>	✓	✓	1A
Los Angeles abrasion	<a href="#">Tex-410-A</a>		✓	TxDOT
Magnesium sulfate soundness	<a href="#">Tex-411-A</a>		✓	TxDOT
Micro-Deval abrasion	<a href="#">Tex-461-A</a>		✓	2
Crushed face count	<a href="#">Tex-460-A</a>	✓	✓	2
Flat and elongated particles	<a href="#">Tex-280-F</a>	✓	✓	2
Linear shrinkage	<a href="#">Tex-107-E</a>	✓	✓	2
Sand equivalent	<a href="#">Tex-203-F</a>	✓	✓	2
Organic impurities	<a href="#">Tex-408-A</a>	✓	✓	2
<b>2. Asphalt Binder &amp; Tack Coat Sampling</b>				
Asphalt binder sampling	<a href="#">Tex-500-C, Part II</a>	✓	✓	1A/1B
Tack coat sampling	<a href="#">Tex-500-C, Part III</a>	✓	✓	1A/1B
<b>3. Mix Design &amp; Verification</b>				
Design and JMF changes	<a href="#">Tex-204-F</a>	✓	✓	2
Mixing	<a href="#">Tex-205-F</a>	✓	✓	2
Molding (TGC)	<a href="#">Tex-206-F</a>	✓	✓	1A
Molding (SGC)	<a href="#">Tex-241-F</a>	✓	✓	1A
Laboratory-molded density	<a href="#">Tex-207-F</a>	✓	✓	1A
VMA <sup>2</sup> (calculation only)	<a href="#">Tex-204-F</a>	✓	✓	2
Rice gravity	<a href="#">Tex-227-F</a>	✓	✓	1A
Ignition oven correction factors <sup>3</sup>	<a href="#">Tex-236-F</a>	✓	✓	2
Indirect tensile strength	<a href="#">Tex-226-F</a>	✓	✓	2
Hamburg Wheel test	<a href="#">Tex-242-F</a>	✓	✓	2
Boil test	<a href="#">Tex-530-C</a>	✓	✓	1A
<b>4. Production Testing</b>				
Selecting production random numbers	<a href="#">Tex-225-F, Part I</a>		✓	1A
Mixture sampling	<a href="#">Tex-222-F</a>	✓	✓	1A
Molding (TGC)	<a href="#">Tex-206-F</a>	✓	✓	1A
Molding (SGC)	<a href="#">Tex-241-F</a>	✓	✓	1A
Laboratory-molded density	<a href="#">Tex-207-F</a>	✓	✓	1A
VMA <sup>2</sup> (calculation only)	<a href="#">Tex-204-F</a>	✓	✓	1A
Rice gravity	<a href="#">Tex-227-F</a>	✓	✓	1A
Gradation & asphalt binder content <sup>3</sup>	<a href="#">Tex-236-F</a>	✓	✓	1A
Control charts	<a href="#">Tex-233-F</a>	✓	✓	1A
Moisture content	<a href="#">Tex-212-F</a>	✓	✓	1A
Hamburg Wheel test	<a href="#">Tex-242-F</a>	✓	✓	2
Micro-Deval abrasion	<a href="#">Tex-461-A</a>		✓	2
Boil test	<a href="#">Tex-530-C</a>	✓	✓	1A
Abson recovery	<a href="#">Tex-211-F</a>		✓	TxDOT
Overlay test	<a href="#">Tex-248-F</a>		✓	TxDOT
Cantabro loss	<a href="#">Tex-245-F</a>		✓	2
<b>5. Placement Testing</b>				
Selecting placement random numbers	<a href="#">Tex-225-F, Part II</a>		✓	1A/1B
Trimming roadway cores	<a href="#">Tex-207-F</a>	✓	✓	1A/1B
In-place air voids	<a href="#">Tex-207-F</a>	✓	✓	1A/1B
Establish rolling pattern	<a href="#">Tex-207-F</a>	✓		1B
Control charts	<a href="#">Tex-233-F</a>	✓	✓	1A
Ride quality measurement	<a href="#">Tex-1001-S</a>	✓	✓	Note 4
Segregation (density profile)	<a href="#">Tex-207-F, Part V</a>	✓	✓	1B
Longitudinal joint density	<a href="#">Tex-207-F, Part VII</a>	✓	✓	1B
Thermal profile	<a href="#">Tex-244-F</a>	✓	✓	1B

- Level 1A, 1B, and 2 are certification levels provided by the Hot Mix Asphalt Center certification program.
- voids in mineral aggregates.
- Refer to Section 341.4.9.2.3., "Production Testing," for exceptions to using an ignition oven.
- Profiler and operator are required to be certified at the Texas A&M Transportation Institute facility when Surface Test Type B is specified.

4.2.

**Reporting and Responsibilities.** Use Department-provided templates to record and calculate all test data, including mixture design, production and placement QC/QA, control charts, thermal profiles, segregation density profiles, and longitudinal joint density. Obtain the current version of the templates at <http://www.txdot.gov/inside-txdot/forms-publications/consultants-contractors/forms/site-manager.html> or from the Engineer. The Engineer and the Contractor will provide any available test results to the other party when requested. The maximum allowable time for the Contractor and Engineer to exchange test data is as given in Table 7 unless otherwise approved. The Engineer and the Contractor will immediately report to the other party any test result that requires suspension of production or placement, a payment adjustment less than 1,000, or that fails to meet the specification requirements. Record and electronically submit all test results and pertinent information on Department-provided templates.

Subsequent sublots placed after test results are available to the Contractor, which require suspension of operations, may be considered unauthorized work. Unauthorized work will be accepted or rejected at the discretion of the Engineer in accordance with Article 5.3., "Conformity with Plans, Specifications, and Special Provisions."

**Table 7**  
**Reporting Schedule**

Description	Reported By	Reported To	To Be Reported Within
<b><i>Production Quality Control</i></b>			
Gradation <sup>1</sup>	Contractor	Engineer	1 working day of completion of the subplot
Asphalt binder content <sup>1</sup>			
Laboratory-molded density <sup>2</sup>			
Moisture content <sup>3</sup>			
Boil test <sup>3</sup>			
<b><i>Production Quality Assurance</i></b>			
Gradation <sup>3</sup>	Engineer	Contractor	1 working day of completion of the subplot
Asphalt binder content <sup>3</sup>			
Laboratory-molded density <sup>1</sup>			
Hamburg Wheel test <sup>2</sup>			
Boil test <sup>3</sup>			
Binder tests <sup>2</sup>			
<b><i>Placement Quality Control</i></b>			
In-place air voids <sup>2</sup>	Contractor	Engineer	1 working day of completion of the lot
Segregation <sup>1</sup>			
Longitudinal joint density <sup>1</sup>			
Thermal profile <sup>1</sup>			
<b><i>Placement Quality Assurance</i></b>			
In-place air voids <sup>1</sup>	Engineer	Contractor	1 working day of receipt of the trimmed cores for in-place air voids <sup>4</sup>
Segregation <sup>2</sup>			
Longitudinal joint density <sup>2</sup>			
Thermal profile <sup>2</sup>			
Aging ratio <sup>2</sup>			
Payment adjustment summary	Engineer	Contractor	2 working days of performing all required tests and receiving Contractor test data

1. These tests are required on every subplot.
2. Optional test. To be reported as soon as results become available.
3. To be performed at the frequency specified on the plans.
4. 2 days are allowed if cores cannot be dried to constant weight within 1 day.

The Engineer will use the Department-provided template to calculate all payment adjustment factors for the lot. Sublot samples may be discarded after the Engineer and Contractor sign off on the payment adjustment summary documentation for the lot.

Use the procedures described in [Tex-233-F](#) to plot the results of all quality control (QC) and quality assurance (QA) testing. Update the control charts as soon as test results for each subplot become available. Make the control charts readily accessible at the field laboratory. The Engineer may suspend production for failure to update control charts.

- 4.3. **Quality Control Plan (QCP).** Develop and follow the QCP in detail. Obtain approval for changes to the QCP made during the project. The Engineer may suspend operations if the Contractor fails to comply with the QCP.
- Submit a written QCP before the mandatory pre-paving meeting. Receive approval of the QCP before beginning production. Include the following items in the QCP:
- 4.3.1. **Project Personnel.** For project personnel, include:
- a list of individuals responsible for QC with authority to take corrective action;
  - current contact information for each individual listed; and
  - current copies of certification documents for individuals performing specified QC functions.
- 4.3.2. **Material Delivery and Storage.** For material delivery and storage, include:
- the sequence of material processing, delivery, and minimum quantities to assure continuous plant operations;
  - aggregate stockpiling procedures to avoid contamination and segregation;
  - frequency, type, and timing of aggregate stockpile testing to assure conformance of material requirements before mixture production; and
  - procedure for monitoring the quality and variability of asphalt binder.
- 4.3.3. **Production.** For production, include:
- loader operation procedures to avoid contamination in cold bins;
  - procedures for calibrating and controlling cold feeds;
  - procedures to eliminate debris or oversized material;
  - procedures for adding and verifying rates of each applicable mixture component (e.g., aggregate, asphalt binder, RAP, RAS, lime, liquid antistriper, WMA);
  - procedures for reporting job control test results; and
  - procedures to avoid segregation and drain-down in the silo.
- 4.3.4. **Loading and Transporting.** For loading and transporting, include:
- type and application method for release agents; and
  - truck loading procedures to avoid segregation.
- 4.3.5. **Placement and Compaction.** For placement and compaction, include:
- proposed agenda for mandatory pre-paving meeting, including date and location;
  - proposed paving plan (e.g., paving widths, joint offsets, and lift thicknesses);
  - type and application method for release agents in the paver and on rollers, shovels, lutes, and other utensils;
  - procedures for the transfer of mixture into the paver, while avoiding segregation and preventing material spillage;
  - process to balance production, delivery, paving, and compaction to achieve continuous placement operations and good ride quality;
  - paver operations (e.g., operation of wings, height of mixture in auger chamber) to avoid physical and thermal segregation and other surface irregularities; and
  - procedures to construct quality longitudinal and transverse joints.
- 4.4. **Mixture Design.**
- 4.4.1. **Design Requirements.** The Contractor may design the mixture using a Texas Gyrotory Compactor (TGC) or a Superpave Gyrotory Compactor (SGC) unless otherwise shown on the plans. Use the dense-graded design procedure provided in [Tex-204-F](#). Design the mixture to meet the requirements listed in Tables 1, 2, 3, 4, 5, 8, 9, and 10.

4.4.1.1. **Target Laboratory-Molded Density When The TGC Is Used.** Design the mixture at a 96.5% target laboratory-molded density. Increase the target laboratory-molded density to 97.0% or 97.5% at the Contractor's discretion or when shown on the plans or specification.

4.4.1.2. **Design Number of Gyration (Ndesign) When The SGC Is Used.** Design the mixture at 50 gyrations (Ndesign). Use a target laboratory-molded density of 96.0% to design the mixture; however, adjustments can be made to the Ndesign value as noted in Table 9. The Ndesign level may be reduced to no less than 35 gyrations at the Contractor's discretion.

Use an approved laboratory from the Department's MPL to perform the Hamburg Wheel test, and provide results with the mixture design, or provide the laboratory mixture and request that the Department perform the Hamburg Wheel test. The Engineer will be allowed 10 working days to provide the Contractor with Hamburg Wheel test results on the laboratory mixture design.

The Engineer will provide the mixture design when shown on the plans. The Contractor may submit a new mixture design at any time during the project. The Engineer will verify and approve all mixture designs (JMF1) before the Contractor can begin production.

Provide the Engineer with a mixture design report using the Department-provided template. Include the following items in the report:

- the combined aggregate gradation, source, specific gravity, and percent of each material used;
- asphalt binder content and aggregate gradation of RAP and RAS stockpiles;
- the target laboratory-molded density (or Ndesign level when using the SGC);
- results of all applicable tests;
- the mixing and molding temperatures;
- the signature of the Level 2 person or persons that performed the design;
- the date the mixture design was performed; and
- a unique identification number for the mixture design.

**Table 8**  
**Master Gradation Limits (% Passing by Weight or Volume) and VMA Requirements**

Sieve Size	A Coarse Base	B Fine Base	C Coarse Surface	D Fine Surface	F Fine Mixture
2"	100.0 <sup>1</sup>	—	—	—	—
1-1/2"	98.0–100.0	100.0 <sup>1</sup>	—	—	—
1"	78.0–94.0	98.0–100.0	100.0 <sup>1</sup>	—	—
3/4"	64.0–85.0	84.0–98.0	95.0–100.0	100.0 <sup>1</sup>	—
1/2"	50.0–70.0	—	—	98.0–100.0	100.0 <sup>1</sup>
3/8"	—	60.0–80.0	70.0–85.0	85.0–100.0	98.0–100.0
#4	30.0–50.0	40.0–60.0	43.0–63.0	50.0–70.0	70.0–90.0
#8	22.0–36.0	29.0–43.0	32.0–44.0	35.0–46.0	38.0–48.0
#30	8.0–23.0	13.0–28.0	14.0–28.0	15.0–29.0	12.0–27.0
#50	3.0–19.0	6.0–20.0	7.0–21.0	7.0–20.0	6.0–19.0
#200	2.0–7.0	2.0–7.0	2.0–7.0	2.0–7.0	2.0–7.0
<b>Design VMA, % Minimum</b>					
—	12.0	13.0	14.0	15.0	16.0
<b>Production (Plant-Produced) VMA, % Minimum</b>					
—	11.5	12.5	13.5	14.5	15.5

1. Defined as maximum sieve size. No tolerance allowed.

**Table 9**  
**Laboratory Mixture Design Properties**

Mixture Property	Test Method	Requirement
Target laboratory-molded density, % (TGC)	<a href="#">Tex-207-F</a>	96.5 <sup>1</sup>
Design gyrations (Ndesign for SGC)	<a href="#">Tex-241-F</a>	50 <sup>2</sup>
Indirect tensile strength (dry), psi	<a href="#">Tex-226-F</a>	85–200 <sup>3</sup>
Boil test <sup>4</sup>	<a href="#">Tex-530-C</a>	–

- Increase to 97.0% or 97.5% at the Contractor's discretion or when shown on the plans or specification.
- Adjust within a range of 35–100 gyrations when shown on the plans or specification or when mutually agreed between the Engineer and Contractor.
- The Engineer may allow the IDT strength to exceed 200 psi if the corresponding Hamburg Wheel rut depth is greater than 3.0 mm and less than 12.5 mm.
- Used to establish baseline for comparison to production results. May be waived when approved.

**Table 10**  
**Hamburg Wheel Test Requirements**

High-Temperature Binder Grade	Test Method	Minimum # of Passes @ 12.5 mm <sup>1</sup> Rut Depth, Tested @ 50°C
PG 64 or lower	<a href="#">Tex-242-F</a>	10,000 <sup>2</sup>
PG 70		15,000 <sup>3</sup>
PG 76 or higher		20,000

- When the rut depth at the required minimum number of passes is less than 3 mm, the Engineer may require the Contractor to increase the target laboratory-molded density (TGC) by 0.5% to no more than 97.5% or lower the Ndesign level (SGC) to no less than 35 gyrations.
- May be decreased to no less than 5,000 passes when shown on the plans.
- May be decreased to no less than 10,000 passes when shown on the plans.

4.4.2. **Job-Mix Formula Approval.** The job-mix formula (JMF) is the combined aggregate gradation, target laboratory-molded density (or Ndesign level), and target asphalt percentage used to establish target values for hot-mix production. JMF1 is the original laboratory mixture design used to produce the trial batch. When WMA is used, JMF1 may be designed and submitted to the Engineer without including the WMA additive. When WMA is used, document the additive or process used and recommended rate on the JMF1 submittal. The Engineer and the Contractor will verify JMF1 based on plant-produced mixture from the trial batch unless otherwise approved. The Engineer may accept an existing mixture design previously used on a Department project and may waive the trial batch to verify JMF1. The Department may require the Contractor to reimburse the Department for verification tests if more than 2 trial batches per design are required.

4.4.2.1. **Contractor's Responsibilities.**

4.4.2.1.1. **Providing Gyrotory Compactor.** Use a TGC calibrated in accordance with [Tex-914-K](#) when electing or required to design the mixture in accordance with [Tex-204-F](#), Part I, for molding production samples. Furnish an SGC calibrated in accordance with [Tex-241-F](#) when electing or required to design the mixture in accordance with [Tex-204-F](#), Part IV, for molding production samples. Locate the SGC, if used, at the Engineer's field laboratory and make the SGC available to the Engineer for use in molding production samples.

4.4.2.1.2. **Gyrotory Compactor Correlation Factors.** Use [Tex-206-F](#), Part II, to perform a gyrotory compactor correlation when the Engineer uses a different gyrotory compactor. Apply the correlation factor to all subsequent production test results.

4.4.2.1.3. **Submitting JMF1.** Furnish a mix design report (JMF1) with representative samples of all component materials and request approval to produce the trial batch. Provide approximately 10,000 g of the design mixture if opting to have the Department perform the Hamburg Wheel test on the laboratory mixture, and request that the Department perform the test.

4.4.2.1.4. **Supplying Aggregates.** Provide approximately 40 lb. of each aggregate stockpile unless otherwise directed.

- 4.4.2.1.5. **Supplying Asphalt.** Provide at least 1 gal. of the asphalt material and sufficient quantities of any additives proposed for use.
- 4.4.2.1.6. **Ignition Oven Correction Factors.** Determine the aggregate and asphalt correction factors from the ignition oven in accordance with [Tex-236-F](#). Provide the Engineer with split samples of the mixtures before the trial batch production, including all additives (except water), and blank samples used to determine the correction factors for the ignition oven used for QA testing during production. Correction factors established from a previously approved mixture design may be used for the current mixture design if the mixture design and ignition oven are the same as previously used, unless otherwise directed.
- 4.4.2.1.7. **Boil Test.** Perform the test and retain the tested sample from [Tex-530-C](#) until completion of the project or as directed. Use this sample for comparison purposes during production. The Engineer may waive the requirement for the boil test.
- 4.4.2.1.8. **Trial Batch Production.** Provide a plant-produced trial batch upon receiving conditional approval of JMF1 and authorization to produce a trial batch, including the WMA additive or process if applicable, for verification testing of JMF1 and development of JMF2. Produce a trial batch mixture that meets the requirements in Table 4, Table 5, and Table 11. The Engineer may accept test results from recent production of the same mixture instead of a new trial batch.
- 4.4.2.1.9. **Trial Batch Production Equipment.** Use only equipment and materials proposed for use on the project to produce the trial batch.
- 4.4.2.1.10. **Trial Batch Quantity.** Produce enough quantity of the trial batch to ensure that the mixture meets the specification requirements.
- 4.4.2.1.11. **Number of Trial Batches.** Produce trial batches as necessary to obtain a mixture that meets the specification requirements.
- 4.4.2.1.12. **Trial Batch Sampling.** Obtain a representative sample of the trial batch and split it into 3 equal portions in accordance with [Tex-222-F](#). Label these portions as “Contractor,” “Engineer,” and “Referee.” Deliver samples to the appropriate laboratory as directed.
- 4.4.2.1.13. **Trial Batch Testing.** Test the trial batch to ensure the mixture produced using the proposed JMF1 meets the mixture requirements in Table 11. Ensure the trial batch mixture is also in compliance with the Hamburg Wheel requirement in Table 10. Use a Department-approved laboratory to perform the Hamburg Wheel test on the trial batch mixture or request that the Department perform the Hamburg Wheel test. The Engineer will be allowed 10 working days to provide the Contractor with Hamburg Wheel test results on the trial batch. Provide the Engineer with a copy of the trial batch test results.
- 4.4.2.1.14. **Development of JMF2.** Evaluate the trial batch test results after the Engineer grants full approval of JMF1 based on results from the trial batch, determine the optimum mixture proportions, and submit as JMF2. Adjust the asphalt binder content or gradation to achieve the specified target laboratory-molded density. The asphalt binder content established for JMF2 is not required to be within any tolerance of the optimum asphalt binder content established for JMF1; however, mixture produced using JMF2 must meet the voids in mineral aggregates (VMA) requirements for production shown in Table 8. If the optimum asphalt binder content for JMF2 is more than 0.5% lower than the optimum asphalt binder content for JMF1, the Engineer may perform or require the Contractor to perform [Tex-226-F](#) on Lot 1 production to confirm the indirect tensile strength does not exceed 200 psi. Verify that JMF2 meets the mixture requirements in Table 5.
- 4.4.2.1.15. **Mixture Production.** Use JMF2 to produce Lot 1 as described in Section 341.4.9.3.1.1., “Lot 1 Placement,” after receiving approval for JMF2 and a passing result from the Department’s or a Department-approved laboratory’s Hamburg Wheel test on the trial batch. If desired, proceed to Lot 1 production, once JMF2 is approved, at the Contractor’s risk without receiving the results from the Department’s Hamburg Wheel test on the trial batch.



Notify the Engineer if electing to proceed without Hamburg Wheel test results from the trial batch. Note that the Engineer may require up to the entire subplot of any mixture failing the Hamburg Wheel test to be removed and replaced at the Contractor's expense.

- 4.4.2.1.16. **Development of JMF3.** Evaluate the test results from Lot 1, determine the optimum mixture proportions, and submit as JMF3 for use in Lot 2.
- 4.4.2.1.17. **JMF Adjustments.** If JMF adjustments are necessary to achieve the specified requirements, make the adjustments before beginning a new lot. The adjusted JMF must:
- be provided to the Engineer in writing before the start of a new lot;
  - be numbered in sequence to the previous JMF;
  - meet the mixture requirements in Table 4 and Table 5;
  - meet the master gradation limits shown in Table 8; and
  - be within the operational tolerances of JMF2 listed in Table 11.
- 4.4.2.1.18. **Requesting Referee Testing.** Use referee testing, if needed, in accordance with Section 341.4.9.1., "Referee Testing," to resolve testing differences with the Engineer.

**Table 11**  
**Operational Tolerances**

Description	Test Method	Allowable Difference Between Trial Batch and JMF1 Target	Allowable Difference from Current JMF Target	Allowable Difference between Contractor and Engineer <sup>1</sup>
Individual % retained for #8 sieve and larger	<a href="#">Tex-200-F</a> or <a href="#">Tex-236-F</a>	Must be Within Master Grading Limits in Table 8	$\pm 5.0^{2,3}$	$\pm 5.0$
Individual % retained for sieves smaller than #8 and larger than #200			$\pm 3.0^{2,3}$	$\pm 3.0$
% passing the #200 sieve			$\pm 2.0^{2,3}$	$\pm 1.6$
Asphalt binder content, %	<a href="#">Tex-236-F</a>	$\pm 0.5$	$\pm 0.3^3$	$\pm 0.3$
Laboratory-molded density, %	<a href="#">Tex-207-F</a>	$\pm 1.0$	$\pm 1.0$	$\pm 1.0$
In-place air voids, %		N/A	N/A	$\pm 1.0$
Laboratory-molded bulk specific gravity		N/A	N/A	$\pm 0.020$
VMA, %, min	<a href="#">Tex-204-F</a>	Note 4	Note 4	N/A
Theoretical maximum specific (Rice) gravity	<a href="#">Tex-227-F</a>	N/A	N/A	$\pm 0.020$

1. Contractor may request referee testing only when values exceed these tolerances.
2. When within these tolerances, mixture production gradations may fall outside the master grading limits; however, the % passing the #200 will be considered out of tolerance when outside the master grading limits.
3. Only applies to mixture produced for Lot 1 and higher.
4. Test and verify that Table 8 requirements are met.

#### 4.4.2.2. **Engineer's Responsibilities.**

- 4.4.2.2.1. **Gyratory Compactor.** For mixtures designed in accordance with [Tex-204-F](#), Part I, the Engineer will use a Department TGC, calibrated in accordance with [Tex-914-K](#), to mold samples for trial batch and production testing. The Engineer will make the Department TGC and the Department field laboratory available to the Contractor for molding verification samples, if requested by the Contractor.

For mixtures designed in accordance with [Tex-204-F](#), Part IV, the Engineer will use a Department SGC, calibrated in accordance with [Tex-241-F](#), to mold samples for laboratory mixture design verification. For molding trial batch and production specimens, the Engineer will use the Contractor-provided SGC at the field laboratory or provide and use a Department SGC at an alternate location. The Engineer will make the Contractor-provided SGC in the Department field laboratory available to the Contractor for molding verification samples.

- 4.4.2.2.2. **Conditional Approval of JMF1 and Authorizing Trial Batch.** The Engineer will review and verify conformance of the following information within 2 working days of receipt:
- the Contractor's mix design report (JMF1);
  - the Contractor-provided Hamburg Wheel test results;
  - all required materials including aggregates, asphalt, additives, and recycled materials; and

- the mixture specifications.

The Engineer will grant the Contractor conditional approval of JMF1 if the information provided on the paper copy of JMF1 indicates that the Contractor's mixture design meets the specifications. When the Contractor does not provide Hamburg Wheel test results with laboratory mixture design, 10 working days are allowed for conditional approval of JMF1. The Engineer will base full approval of JMF1 on the test results on mixture from the trial batch.

Unless waived, the Engineer will determine the Micro-Deval abrasion loss in accordance with Section 341.2.1.1.2., "Micro-Deval Abrasion." If the Engineer's test results are pending after 2 working days, conditional approval of JMF1 will still be granted within 2 working days of receiving JMF1. When the Engineer's test results become available, they will be used for specification compliance.

After conditionally approving JMF1, including either Contractor- or Department-supplied Hamburg Wheel test results, the Contractor is authorized to produce a trial batch.

4.4.2.2.3. **Hamburg Wheel Testing of JMF1.** If the Contractor requests the option to have the Department perform the Hamburg Wheel test on the laboratory mixture, the Engineer will mold samples in accordance with [Tex-242-F](#) to verify compliance with the Hamburg Wheel test requirement in Table 10.

4.4.2.2.4. **Ignition Oven Correction Factors.** The Engineer will use the split samples provided by the Contractor to determine the aggregate and asphalt correction factors for the ignition oven used for QA testing during production in accordance with [Tex-236-F](#).

4.4.2.2.5. **Testing the Trial Batch.** Within 1 full working day, the Engineer will sample and test the trial batch to ensure that the mixture meets the requirements in Table 11. If the Contractor requests the option to have the Department perform the Hamburg Wheel test on the trial batch mixture, the Engineer will mold samples in accordance with [Tex-242-F](#) to verify compliance with the Hamburg Wheel test requirement in Table 10.

The Engineer will have the option to perform the following tests on the trial batch:

- [Tex-226-F](#), to verify that the indirect tensile strength meets the requirement shown in Table 9; and
- [Tex-530-C](#), to retain and use for comparison purposes during production.

4.4.2.2.6. **Full Approval of JMF1.** The Engineer will grant full approval of JMF1 and authorize the Contractor to proceed with developing JMF2 if the Engineer's results for the trial batch meet the requirements in Table 11. The Engineer will notify the Contractor that an additional trial batch is required if the trial batch does not meet these requirements.

4.4.2.2.7. **Approval of JMF2.** The Engineer will approve JMF2 within one working day if the mixture meets the requirements in Table 5 and the gradation meets the master grading limits shown in Table 8. The asphalt binder content established for JMF2 is not required to be within any tolerance of the optimum asphalt binder content established for JMF1; however, mixture produced using JMF2 must meet the VMA requirements shown in Table 8. If the optimum asphalt binder content for JMF2 is more than 0.5% lower than the optimum asphalt binder content for JMF1, the Engineer may perform or require the Contractor to perform [Tex-226-F](#) on Lot 1 production to confirm the indirect tensile strength does not exceed 200 psi.

4.4.2.2.8. **Approval of Lot 1 Production.** The Engineer will authorize the Contractor to proceed with Lot 1 production (using JMF2) as soon as a passing result is achieved from the Department's or a Department-approved laboratory's Hamburg Wheel test on the trial batch. The Contractor may proceed at its own risk with Lot 1 production without the results from the Hamburg Wheel test on the trial batch.

If the Department's or Department-approved laboratory's sample from the trial batch fails the Hamburg Wheel test, the Engineer will suspend production until further Hamburg Wheel tests meet the specified values. The Engineer may require up to the entire subplot of any mixture failing the Hamburg Wheel test be removed and replaced at the Contractor's expense.

- 4.4.2.2.9. **Approval of JMF3 and Subsequent JMF Changes.** JMF3 and subsequent JMF changes are approved if they meet the mixture requirements shown in Table 4, Table 5, and the master grading limits shown in Table 8, and are within the operational tolerances of JMF2 shown in Table 11.
- 4.5. **Production Operations.** Perform a new trial batch when the plant or plant location is changed. Take corrective action and receive approval to proceed after any production suspension for noncompliance to the specification. Submit a new mix design and perform a new trial batch when the asphalt binder content of:
- any RAP stockpile used in the mix is more than 0.5% higher than the value shown on the mixture design report; or
  - RAS stockpile used in the mix is more than 2.0% higher than the value shown on the mixture design report.
- 4.5.1. **Storage and Heating of Materials.** Do not heat the asphalt binder above the temperatures specified in Item 300, "Asphalts, Oils, and Emulsions," or outside the manufacturer's recommended values. Provide the Engineer with daily records of asphalt binder and hot-mix asphalt discharge temperatures (in legible and discernible increments) in accordance with Item 320, "Equipment for Asphalt Concrete Pavement," unless otherwise directed. Do not store mixture for a period long enough to affect the quality of the mixture, nor in any case longer than 12 hr. unless otherwise approved.
- 4.5.2. **Mixing and Discharge of Materials.** Notify the Engineer of the target discharge temperature and produce the mixture within 25°F of the target. Monitor the temperature of the material in the truck before shipping to ensure that it does not exceed 350°F (or 275°F for WMA) and is not lower than 215°F. The Department will not pay for or allow placement of any mixture produced above 350°F.
- Produce WMA within the target discharge temperature range of 215°F and 275°F when WMA is required. Take corrective action any time the discharge temperature of the WMA exceeds the target discharge range. The Engineer may suspend production operations if the Contractor's corrective action is not successful at controlling the production temperature within the target discharge range. Note that when WMA is produced, it may be necessary to adjust burners to ensure complete combustion such that no burner fuel residue remains in the mixture.
- Control the mixing time and temperature so that substantially all moisture is removed from the mixture before discharging from the plant. Determine the moisture content, if requested, by oven-drying in accordance with [Tex-212-F](#), Part II, and verify that the mixture contains no more than 0.2% of moisture by weight. Obtain the sample immediately after discharging the mixture into the truck, and perform the test promptly.
- 4.6. **Hauling Operations.** Clean all truck beds before use to ensure that mixture is not contaminated. Use a release agent shown on the Department's MPL to coat the inside bed of the truck when necessary.
- Use equipment for hauling as defined in Section 341.4.7.3.3., "Hauling Equipment." Use other hauling equipment only when allowed.
- 4.7. **Placement Operations.** Collect haul tickets from each load of mixture delivered to the project and provide the Department's copy to the Engineer approximately every hour, or as directed. Use a hand-held thermal camera or infrared thermometer, when a thermal imaging system is not used, to measure and record the internal temperature of the mixture as discharged from the truck or Material Transfer Device (MTD) before or as the mix enters the paver and an approximate station number or GPS coordinates on each ticket. Calculate the daily yield and cumulative yield for the specified lift and provide to the Engineer at the end of paving operations for each day unless otherwise directed. The Engineer may suspend production if the Contractor fails to produce and provide haul tickets and yield calculations by the end of paving operations for each day.
- Prepare the surface by removing raised pavement markers and objectionable material such as moisture, dirt, sand, leaves, and other loose impediments from the surface before placing mixture. Remove vegetation from pavement edges. Place the mixture to meet the typical section requirements and produce a smooth, finished surface with a uniform appearance and texture. Offset longitudinal joints of successive courses of hot-mix by at least 6 in. Place mixture so that longitudinal joints on the surface course coincide with lane lines, or as

directed. Ensure that all finished surfaces will drain properly. Place the mixture at the rate or thickness shown on the plans. The Engineer will use the guidelines in Table 12 to determine the compacted lift thickness of each layer when multiple lifts are required. The thickness determined is based on the rate of 110 lb./sq. yd. for each inch of pavement unless otherwise shown on the plans.

**Table 12**  
**Compacted Lift Thickness and Required Core Height**

Mixture Type	Compacted Lift Thickness Guidelines		Minimum Untrimmed Core Height (in.) Eligible for Testing
	Minimum (in.)	Maximum (in.)	
A	3.00	6.00	2.00
B	2.50	5.00	1.75
C	2.00	4.00	1.50
D	1.50	3.00	1.25
F	1.25	2.50	1.25

#### 4.7.1. Weather Conditions.

4.7.1.1. **When Using a Thermal Imaging System.** The Contractor may pave any time the roadway is dry and the roadway surface temperature is at least 32°F; however, the Engineer may restrict the Contractor from paving surface mixtures if the ambient temperature is likely to drop below 32°F within 12 hr. of paving. Provide output data from the thermal imaging system to demonstrate to the Engineer that no recurring severe thermal segregation exists in accordance with Section 341.4.7.3.1.2., "Thermal Imaging System."

4.7.1.2. **When Not Using a Thermal Imaging System.** Place mixture when the roadway surface temperature is at or above the temperatures listed in Table 13 unless otherwise approved or as shown on the plans. Measure the roadway surface temperature with a hand-held thermal camera or infrared thermometer. The Engineer may allow mixture placement to begin before the roadway surface reaches the required temperature if conditions are such that the roadway surface will reach the required temperature within 2 hr. of beginning placement operations. Place mixtures only when weather conditions and moisture conditions of the roadway surface are suitable as determined by the Engineer. The Engineer may restrict the Contractor from paving if the ambient temperature is likely to drop below 32°F within 12 hr. of paving.

**Table 13**  
**Minimum Pavement Surface Temperatures**

Originally Specified High Temperature Binder Grade	Minimum Pavement Surface Temperatures (°F)	
	Subsurface Layers or Night Paving Operations	Surface Layers Placed in Daylight Operations
PG 64 or lower	45	50
PG 70	55 <sup>1</sup>	60 <sup>1</sup>
PG 76 or higher	60 <sup>1</sup>	60 <sup>1</sup>

- Contractors may pave at temperatures 10°F lower than these values when utilizing a paving process including WMA or equipment that eliminates thermal segregation. In such cases, use a hand-held thermal camera operated in accordance with [Tex-244-F](#) to demonstrate to the satisfaction of the Engineer that the uncompacted mat has no more than 10°F of thermal segregation.

4.7.2. **Tack Coat.** Clean the surface before placing the tack coat. The Engineer will set the rate between 0.04 and 0.10 gal. of residual asphalt per square yard of surface area. Apply a uniform tack coat at the specified rate unless otherwise directed. Apply the tack coat in a uniform manner to avoid streaks and other irregular patterns. Apply a thin, uniform tack coat to all contact surfaces of curbs, structures, and all joints. Allow adequate time for emulsion to break completely before placing any material. Prevent splattering of tack coat when placed adjacent to curb, gutter, and structures. Roll the tack coat with a pneumatic-tire roller to remove streaks and other irregular patterns when directed.

#### 4.7.3. Lay-Down Operations.

4.7.3.1. **Thermal Profile.** Use a hand-held thermal camera or a thermal imaging system to obtain a continuous thermal profile in accordance with [Tex-244-F](#). Thermal profiles are not applicable in areas described in Section 341.4.9.3.1.4., "Miscellaneous Areas."

#### 4.7.3.1.1. Thermal Segregation.

- 4.7.3.1.1.1. **Moderate.** Any areas that have a temperature differential greater than 25°F, but not exceeding 50°F, are deemed as having moderate thermal segregation.
- 4.7.3.1.1.2. **Severe.** Any areas that have a temperature differential greater than 50°F are deemed as having severe thermal segregation.
- 4.7.3.1.2. **Thermal Imaging System.** Review the output results when a thermal imaging system is used, and provide the automated report described in [Tex-244-F](#) to the Engineer daily unless otherwise directed. Modify the paving process as necessary to eliminate any recurring (moderate or severe) thermal segregation identified by the thermal imaging system. The Engineer may suspend paving operations if the Contractor cannot successfully modify the paving process to eliminate recurring severe thermal segregation. Density profiles are not required and not applicable when using a thermal imaging system. Provide the Engineer with electronic copies of all daily data files that can be used with the thermal imaging system software to generate temperature profile plots upon completion of the project or as requested by the Engineer.
- 4.7.3.1.3. **Thermal Camera.** Take immediate corrective action to eliminate recurring moderate thermal segregation when a hand-held thermal camera is used. Evaluate areas with moderate thermal segregation by performing density profiles in accordance with Section 341.4.9.3.3.2., "Segregation (Density Profile)." Provide the Engineer with the thermal profile of every subplot within one working day of the completion of each lot. Report the results of each thermal profile in accordance with Section 341.4.2., "Reporting and Responsibilities." The Engineer will use a hand-held thermal camera to obtain a thermal profile at least once per project. No production or placement payment adjustments greater than 1.000 will be paid for any subplot that contains severe thermal segregation. Suspend operations and take immediate corrective action to eliminate severe thermal segregation unless otherwise directed. Resume operations when the Engineer determines that subsequent production will meet the requirements of this Section. Evaluate areas with severe thermal segregation by performing density profiles in accordance with Section 341.4.9.3.3.2., "Segregation (Density Profile)." Remove and replace the material in any areas that have both severe thermal segregation and a failing result for Segregation (Density Profile) unless otherwise directed. The subplot in question may receive a production and placement payment adjustment greater than 1.000, if applicable, when the defective material is successfully removed and replaced.
- 4.7.3.2. **Windrow Operations.** Operate windrow pickup equipment so that when hot-mix is placed in windrows, substantially all the mixture deposited on the roadbed is picked up and loaded into the paver.
- 4.7.3.3. **Hauling Equipment.** Use belly dumps, live bottom, or end dump trucks to haul and transfer mixture; however, with exception of paving miscellaneous areas, end dump trucks are only allowed when used in conjunction with an MTD with remixing capability or when a thermal imaging system is used unless otherwise allowed.
- 4.7.3.4. **Screed Heaters.** Turn off screed heaters to prevent overheating of the mat if the paver stops for more than 5 min. The Engineer may evaluate the suspect area in accordance with Section 341.4.9.3.3.4., "Recovered Asphalt Dynamic Shear Rheometer (DSR)," if the screed heater remains on for more than 5 min. while the paver is stopped.
- 4.8. **Compaction.** Compact the pavement uniformly to contain between 3.8% and 8.5% in-place air voids. Take immediate corrective action to bring the operation within 3.8% and 8.5% when the in-place air voids exceed the range of these tolerances. The Engineer will allow paving to resume when the proposed corrective action is likely to yield between 3.8% and 8.5% in-place air voids.

Obtain cores in areas placed under Exempt Production, as directed, at locations determined by the Engineer. The Engineer may test these cores and suspend operations or require removal and replacement if the in-place air voids are less than 2.7% or more than 9.9%. Areas defined in Section 341.4.9.3.1.4., "Miscellaneous Areas," are not subject to in-place air void determination.

Furnish the type, size, and number of rollers required for compaction as approved. Use a pneumatic-tire roller to seal the surface unless excessive pickup of fines occurs. Use additional rollers as required to

remove any roller marks. Use only water or an approved release agent on rollers, tamps, and other compaction equipment unless otherwise directed.

Use the control strip method shown in [Tex-207-F](#), Part IV, on the first day of production to establish the rolling pattern that will produce the desired in-place air voids unless otherwise directed.

Use tamps to thoroughly compact the edges of the pavement along curbs, headers, and similar structures and in locations that will not allow thorough compaction with rollers. The Engineer may require rolling with a trench roller on widened areas, in trenches, and in other limited areas.

Complete all compaction operations before the pavement temperature drops below 160°F unless otherwise allowed. The Engineer may allow compaction with a light finish roller operated in static mode for pavement temperatures below 160°F.

Allow the compacted pavement to cool to 160°F or lower before opening to traffic unless otherwise directed. Sprinkle the finished mat with water or limewater, when directed, to expedite opening the roadway to traffic.

- 4.9. **Acceptance Plan.** Payment adjustments for the material will be in accordance with Article 341.6., "Payment."

Sample and test the hot-mix on a lot and subplot basis. Suspend production until test results or other information indicates to the satisfaction of the Engineer that the next material produced or placed will result in payment factors of at least 1.000, if the production payment factor given in Section 341.6.1., "Production Payment Adjustment Factors," for 2 consecutive lots or the placement pay factor given in Section 341.6.2., "Placement Payment Adjustment Factors," for 2 consecutive lots is below 1.000.

- 4.9.1. **Referee Testing.** The Construction Division is the referee laboratory. The Contractor may request referee testing if a "remove and replace" condition is determined based on the Engineer's test results, or if the differences between Contractor and Engineer test results exceed the maximum allowable difference shown in Table 11 and the differences cannot be resolved. The Contractor may also request referee testing if the Engineer's test results require suspension of production and the Contractor's test results are within specification limits. Make the request within 5 working days after receiving test results and cores from the Engineer. Referee tests will be performed only on the subplot in question and only for the particular tests in question. Allow 10 working days from the time the referee laboratory receives the samples for test results to be reported. The Department may require the Contractor to reimburse the Department for referee tests if more than 3 referee tests per project are required and the Engineer's test results are closer to the referee test results than the Contractor's test results.

The Construction Division will determine the laboratory-molded density based on the molded specific gravity and the maximum theoretical specific gravity of the referee sample. The in-place air voids will be determined based on the bulk specific gravity of the cores, as determined by the referee laboratory and the Engineer's average maximum theoretical specific gravity for the lot. With the exception of "remove and replace" conditions, referee test results are final and will establish payment adjustment factors for the subplot in question. The Contractor may decline referee testing and accept the Engineer's test results when the placement payment adjustment factor for any subplot results in a "remove and replace" condition. Placement sublots subject to be removed and replaced will be further evaluated in accordance with Section 341.6.2.2., "Placement Sublots Subject to Removal and Replacement."

- 4.9.2. **Production Acceptance.**

- 4.9.2.1. **Production Lot.** A production lot consists of 4 equal sublots. The default quantity for Lot 1 is 1,000 tons; however, when requested by the Contractor, the Engineer may increase the quantity for Lot 1 to no more than 4,000 tons. The Engineer will select subsequent lot sizes based on the anticipated daily production such that approximately 3 to 4 sublots are produced each day. The lot size will be between 1,000 tons and 4,000 tons. The Engineer may change the lot size before the Contractor begins any lot.

If the optimum asphalt binder content for JMF2 is more than 0.5% lower than the optimum asphalt binder content for JMF1, the Engineer may perform or require the Contractor to perform [Tex-226-F](#) on Lot 1 to confirm the indirect tensile strength does not exceed 200 psi. Take corrective action to bring the mixture within specification compliance if the indirect tensile strength exceeds 200 psi unless otherwise directed.

- 4.9.2.1.1. **Incomplete Production Lots.** If a lot is begun but cannot be completed, such as on the last day of production or in other circumstances deemed appropriate, the Engineer may close the lot. Adjust the payment for the incomplete lot in accordance with Section 341.6.1., "Production Payment Adjustment Factors." Close all lots within 5 working days unless otherwise allowed.
- 4.9.2.2. **Production Sampling.**
- 4.9.2.2.1. **Mixture Sampling.** Obtain hot-mix samples from trucks at the plant in accordance with [Tex-222-F](#). The sampler will split each sample into 3 equal portions in accordance with [Tex-200-F](#) and label these portions as "Contractor," "Engineer," and "Referee." The Engineer will perform or witness the sample splitting and take immediate possession of the samples labeled "Engineer" and "Referee." The Engineer will maintain the custody of the samples labeled "Engineer" and "Referee" until the Department's testing is completed.
- 4.9.2.2.1.1. **Random Sample.** At the beginning of the project, the Engineer will select random numbers for all production sublots. Determine sample locations in accordance with [Tex-225-F](#). Take one sample for each subplot at the randomly selected location. The Engineer will perform or witness the sampling of production sublots.
- 4.9.2.2.1.2. **Blind Sample.** For one subplot per lot, the Engineer will obtain and test a "blind" sample instead of the random sample collected by the Contractor. Test either the "blind" or the random sample; however, referee testing (if applicable) will be based on a comparison of results from the "blind" sample. The location of the Engineer's "blind" sample will not be disclosed to the Contractor. The Engineer's "blind" sample may be randomly selected in accordance with [Tex-225-F](#) for any subplot or selected at the discretion of the Engineer. The Engineer will use the Contractor's split sample for sublots not sampled by the Engineer.
- 4.9.2.2.2. **Informational Cantabro and Overlay Testing.** When requested or shown on the plans, select one random subplot from Lot 2 or higher for Cantabro and Overlay testing during the first week of production. Obtain and provide the Engineer with approximately 90 lb. (40 kg) of mixture in sealed containers, boxes, or bags labeled with the Control-Section-Job (CSJ), mixture type, lot, and subplot number. The Engineer will ship the mixture to the Construction Division for Cantabro and Overlay testing. Results from these tests will not be used for specification compliance.
- 4.9.2.2.3. **Asphalt Binder Sampling.** Obtain a 1-qt. sample of the asphalt binder for each lot of mixture produced. Obtain the sample at approximately the same time the mixture random sample is obtained. Sample from a port located immediately upstream from the mixing drum or pug mill in accordance with [Tex-500-C](#), Part II. Label the can with the corresponding lot and subplot numbers and deliver the sample to the Engineer. The Engineer may also obtain independent samples. If obtaining an independent asphalt binder sample, the Engineer will split a sample of the asphalt binder with the Contractor. The Engineer will test at least one asphalt binder sample per project to verify compliance with Item 300, "Asphalts, Oils, and Emulsions."
- 4.9.2.3. **Production Testing.** The Contractor and Engineer must perform production tests in accordance with Table 14. The Contractor has the option to verify the Engineer's test results on split samples provided by the Engineer. Determine compliance with operational tolerances listed in Table 11 for all sublots.

Take immediate corrective action if the Engineer's laboratory-molded density on any subplot is less than 95.0% or greater than 98.0% to bring the mixture within these tolerances. The Engineer may suspend operations if the Contractor's corrective actions do not produce acceptable results. The Engineer will allow production to resume when the proposed corrective action is likely to yield acceptable results.

The Engineer may allow alternate methods for determining the asphalt binder content and aggregate gradation if the aggregate mineralogy is such that [Tex-236-F](#) does not yield reliable results. Provide evidence that results from [Tex-236-F](#) are not reliable before requesting permission to use an alternate method unless otherwise directed. Use the applicable test procedure as directed if an alternate test method is allowed.

**Table 14**  
**Production and Placement Testing Frequency**

Description	Test Method	Minimum Contractor Testing Frequency	Minimum Engineer Testing Frequency
Individual % retained for #8 sieve and larger	<a href="#">Tex-200-F</a> or <a href="#">Tex-236-F</a>	1 per subplot	1 per 12 sublots <sup>1</sup>
Individual % retained for sieves smaller than #8 and larger than #200			
% passing the #200 sieve	<a href="#">Tex-207-F</a>	N/A	1 per subplot <sup>1</sup>
Laboratory-molded density			
Laboratory-molded bulk specific gravity			
In-place air voids			
VMA	<a href="#">Tex-204-F</a>	1 per subplot	1 per project
Segregation (density profile) <sup>2</sup>	<a href="#">Tex-207-F</a> , Part V		
Longitudinal joint density	<a href="#">Tex-207-F</a> , Part VII		
Moisture content	<a href="#">Tex-212-F</a> , Part II	When directed	
Theoretical maximum specific (Rice) gravity	<a href="#">Tex-227-F</a>	N/A	1 per subplot <sup>1</sup>
Asphalt binder content	<a href="#">Tex-236-F</a>	1 per subplot	1 per lot <sup>1</sup>
Hamburg Wheel test	<a href="#">Tex-242-F</a>	N/A	1 per project
Recycled Asphalt Shingles (RAS) <sup>3</sup>	<a href="#">Tex-217-F</a> , Part III	N/A	
Thermal profile <sup>2</sup>	<a href="#">Tex-244-F</a>	1 per subplot	
Asphalt binder sampling and testing	<a href="#">Tex-500-C</a>	1 per lot (sample only)	
Tack coat sampling and testing	<a href="#">Tex-500-C</a> , Part III	N/A	
Boil test <sup>4</sup>	<a href="#">Tex-530-C</a>	1 per lot	
Cantabro loss <sup>5</sup>	<a href="#">Tex-245-F</a>	1 per project (sample only)	
Overlay test <sup>5</sup>	<a href="#">Tex-248-F</a>		

1. For production defined in Section 341.4.9.4., "Exempt Production," the Engineer will test one per day if 100 tons or more are produced. For Exempt Production, no testing is required when less than 100 tons are produced.
2. Not required when a thermal imaging system is used.
3. Testing performed by the Construction Division or designated laboratory.
4. The Engineer may reduce or waive the sampling and testing requirements based on a satisfactory test history.
5. Testing performed by the Construction Division and for informational purposes only.

4.9.2.4. **Operational Tolerances.** Control the production process within the operational tolerances listed in Table 11. When production is suspended, the Engineer will allow production to resume when test results or other information indicates the next mixture produced will be within the operational tolerances.

4.9.2.4.1. **Gradation.** Suspend operation and take corrective action if any aggregate is retained on the maximum sieve size shown in Table 8. A subplot is defined as out of tolerance if either the Engineer's or the Contractor's test results are out of operational tolerance. Suspend production when test results for gradation exceed the operational tolerances for 3 consecutive sublots on the same sieve or 4 consecutive sublots on any sieve unless otherwise directed. The consecutive sublots may be from more than one lot.

4.9.2.4.2. **Asphalt Binder Content.** A subplot is defined as out of operational tolerance if either the Engineer's or the Contractor's test results exceed the values listed in Table 11. No production or placement payment adjustments greater than 1.000 will be paid for any subplot that is out of operational tolerance for asphalt binder content. Suspend production and shipment of the mixture if the Engineer's or the Contractor's asphalt binder content deviates from the current JMF by more than 0.5% for any subplot.

4.9.2.4.3. **Voids in Mineral Aggregates (VMA).** The Engineer will determine the VMA for every subplot. For sublots when the Engineer does not determine asphalt binder content, the Engineer will use the asphalt binder content results from QC testing performed by the Contractor to determine VMA.

Take immediate corrective action if the VMA value for any subplot is less than the minimum VMA requirement for production listed in Table 8. Suspend production and shipment of the mixture if the Engineer's VMA results on 2 consecutive sublots are below the minimum VMA requirement for production listed in Table 8. No production or placement payment adjustments greater than 1.000 will be paid for any subplot that does not meet the minimum VMA requirement for production listed in Table 8 based on the Engineer's VMA determination.



Suspend production and shipment of the mixture if the Engineer's VMA result is more than 0.5% below the minimum VMA requirement for production listed in Table 8. In addition to suspending production, the Engineer may require removal and replacement or may allow the subplot to be left in place without payment.

- 4.9.2.4.4. **Hamburg Wheel Test.** The Engineer may perform a Hamburg Wheel test at any time during production, including when the boil test indicates a change in quality from the materials submitted for JMF1. In addition to testing production samples, the Engineer may obtain cores and perform Hamburg Wheel tests on any areas of the roadway where rutting is observed. Suspend production until further Hamburg Wheel tests meet the specified values when the production or core samples fail the Hamburg Wheel test criteria in Table 10. Core samples, if taken, will be obtained from the center of the finished mat or other areas excluding the vehicle wheel paths. The Engineer may require up to the entire subplot of any mixture failing the Hamburg Wheel test to be removed and replaced at the Contractor's expense.

If the Department's or Department approved laboratory's Hamburg Wheel test results in a "remove and replace" condition, the Contractor may request that the Department confirm the results by re-testing the failing material. The Construction Division will perform the Hamburg Wheel tests and determine the final disposition of the material in question based on the Department's test results.

- 4.9.2.5. **Individual Loads of Hot-Mix.** The Engineer can reject individual truckloads of hot-mix. When a load of hot-mix is rejected for reasons other than temperature, contamination, or excessive uncoated particles, the Contractor may request that the rejected load be tested. Make this request within 4 hr. of rejection. The Engineer will sample and test the mixture. If test results are within the operational tolerances shown in Table 11, payment will be made for the load. If test results are not within operational tolerances, no payment will be made for the load.

4.9.3. **Placement Acceptance.**

- 4.9.3.1. **Placement Lot.** A placement lot consists of 4 placement sublots. A placement subplot consists of the area placed during a production subplot.

- 4.9.3.1.1. **Lot 1 Placement.** Placement payment adjustments greater than 1.000 for Lot 1 will be in accordance with Section 341.6.2., "Placement Payment Adjustment Factors"; however, no placement adjustment less than 1.000 will be assessed for any subplot placed in Lot 1 when the in-place air voids are greater than or equal to 2.7% and less than or equal to 9.9%. Remove and replace any subplot with in-place air voids less than 2.7% or greater than 9.9%.

- 4.9.3.1.2. **Incomplete Placement Lots.** An incomplete placement lot consists of the area placed as described in Section 341.4.9.2.1.1., "Incomplete Production Lots," excluding areas defined in Section 341.4.9.3.1.4., "Miscellaneous Areas." Placement sampling is required if the random sample plan for production resulted in a sample being obtained from an incomplete production subplot.

- 4.9.3.1.3. **Shoulders, Ramps, Etc.** Shoulders, ramps, intersections, acceleration lanes, deceleration lanes, and turn lanes are subject to in-place air void determination and payment adjustments unless designated on the plans as not eligible for in-place air void determination. Intersections may be considered miscellaneous areas when determined by the Engineer.

- 4.9.3.1.4. **Miscellaneous Areas.** Miscellaneous areas include areas that typically involve significant handwork or discontinuous paving operations, such as temporary detours, driveways, mailbox turnouts, crossovers, gores, spot level-up areas, and other similar areas. Temporary detours are subject to in-place air void determination when shown on the plans. Miscellaneous areas also include level-ups and thin overlays when the layer thickness specified on the plans is less than the minimum untrimmed core height eligible for testing shown in Table 12. The specified layer thickness is based on the rate of 110 lb./sq. yd. for each inch of pavement unless another rate is shown on the plans. When "level up" is listed as part of the item bid description code, a payment adjustment factor of 1.000 will be assigned for all placement sublots as described in Article 341.6, "Payment." Miscellaneous areas are not eligible for random placement sampling locations. Compact miscellaneous areas in accordance with Section 341.4.8., "Compaction." Miscellaneous

areas are not subject to in-place air void determination, thermal profiles testing, segregation (density profiles), or longitudinal joint density evaluations.

#### 4.9.3.2.

**Placement Sampling.** The Engineer will select random numbers for all placement sublots at the beginning of the project. The Engineer will provide the Contractor with the placement random numbers immediately after the subplot is completed. Mark the roadway location at the completion of each subplot and record the station number. Determine one random sample location for each placement subplot in accordance with [Tex-225-F](#). Adjust the random sample location by no more than necessary to achieve a 2-ft. clearance if the location is within 2 ft. of a joint or pavement edge.

Shoulders, ramps, intersections, acceleration lanes, deceleration lanes, and turn lanes are always eligible for selection as a random sample location; however, if a random sample location falls on one of these areas and the area is designated on the plans as not subject to in-place air void determination, cores will not be taken for the subplot and a 1.000 pay factor will be assigned to that subplot.

Provide the equipment and means to obtain and trim roadway cores on site. On-site is defined as in close proximity to where the cores are taken. Obtain the cores within one working day of the time the placement subplot is completed unless otherwise approved. Obtain two 6-in. diameter cores side-by-side from within 1 ft. of the random location provided for the placement subplot. For Type D and Type F mixtures, 4-in. diameter cores are allowed. Mark the cores for identification, measure and record the untrimmed core height, and provide the information to the Engineer. The Engineer will witness the coring operation and measurement of the core thickness. Visually inspect each core and verify that the current paving layer is bonded to the underlying layer. Take corrective action if an adequate bond does not exist between the current and underlying layer to ensure that an adequate bond will be achieved during subsequent placement operations.

Trim the cores immediately after obtaining the cores from the roadway in accordance with [Tex-207-F](#) if the core heights meet the minimum untrimmed value listed in Table 12. Trim the cores on site in the presence of the Engineer. Use a permanent marker or paint pen to record the lot and subplot numbers on each core as well as the designation as Core A or B. The Engineer may require additional information to be marked on the core and may choose to sign or initial the core. The Engineer will take custody of the cores immediately after they are trimmed and will retain custody of the cores until the Department's testing is completed. Before turning the trimmed cores over to the Engineer, the Contractor may wrap the trimmed cores or secure them in a manner that will reduce the risk of possible damage occurring during transport by the Engineer. After testing, the Engineer will return the cores to the Contractor.

The Engineer may have the cores transported back to the Department's laboratory at the HMA plant via the Contractor's haul truck or other designated vehicle. In such cases where the cores will be out of the Engineer's possession during transport, the Engineer will use Department-provided security bags and the Roadway Core Custody protocol located at <http://www.txdot.gov/business/specifications.htm> to provide a secure means and process that protects the integrity of the cores during transport.

Decide whether to include the pair of cores in the air void determination for that subplot if the core height before trimming is less than the minimum untrimmed value shown in Table 12. Trim the cores as described above before delivering to the Engineer if electing to have the cores included in the air void determination. Deliver untrimmed cores to the Engineer and inform the Engineer of the decision to not have the cores included in air void determination if electing to not have the cores included in air void determination. The placement pay factor for the subplot will be 1.000 if cores will not be included in air void determination.

Instead of the Contractor trimming the cores on site immediately after coring, the Engineer and the Contractor may mutually agree to have the trimming operations performed at an alternate location such as a field laboratory or other similar location. In such cases, the Engineer will take possession of the cores immediately after they are obtained from the roadway and will retain custody of the cores until testing is completed. Either the Department or Contractor representative may perform trimming of the cores. The Engineer will witness all trimming operations in cases where the Contractor representative performs the trimming operation.

Dry the core holes and tack the sides and bottom immediately after obtaining the cores. Fill the hole with the same type of mixture and properly compact the mixture. Repair core holes with other methods when approved.

4.9.3.3. **Placement Testing.** Perform placement tests in accordance with Table 14. After the Engineer returns the cores, the Contractor may test the cores to verify the Engineer's test results for in-place air voids. The allowable differences between the Contractor's and Engineer's test results are listed in Table 11.

4.9.3.3.1. **In-Place Air Voids.** The Engineer will measure in-place air voids in accordance with [Tex-207-F](#) and [Tex-227-F](#). Before drying to a constant weight, cores may be pre-dried using a Corelok or similar vacuum device to remove excess moisture. The Engineer will average the values obtained for all sublots in the production lot to determine the theoretical maximum specific gravity. The Engineer will use the average air void content for in-place air voids.

The Engineer will use the vacuum method to seal the core if required by [Tex-207-F](#). The Engineer will use the test results from the unsealed core to determine the placement payment adjustment factor if the sealed core yields a higher specific gravity than the unsealed core. After determining the in-place air void content, the Engineer will return the cores and provide test results to the Contractor.

4.9.3.3.2. **Segregation (Density Profile).** Test for segregation using density profiles in accordance with [Tex-207-F](#), Part V. Density profiles are not required and are not applicable when using a thermal imaging system. Density profiles are not applicable in areas described in Section 341.4.9.3.1.4., "Miscellaneous Areas."

Perform a density profile every time the paver stops for more than 60 sec. on areas that are identified by either the Contractor or the Engineer as having thermal segregation and on any visibly segregated areas unless otherwise approved. Perform a minimum of one profile per subplot if the paver does not stop for more than 60 sec. and there are no visibly segregated areas or areas that are identified as having thermal segregation.

Provide the Engineer with the density profile of every subplot in the lot within one working day of the completion of each lot. Report the results of each density profile in accordance with Section 341.4.2., "Reporting and Responsibilities."

The density profile is considered failing if it exceeds the tolerances in Table 15. No production or placement payment adjustments greater than 1.000 will be paid for any subplot that contains a failing density profile. When a hand-held thermal camera is used instead of a thermal imaging system, the Engineer will measure the density profile at least once per project. The Engineer's density profile results will be used when available. The Engineer may require the Contractor to remove and replace the area in question if the area fails the density profile and has surface irregularities as defined in Section 341.4.9.3.3.5., "Irregularities." The subplot in question may receive a production and placement payment adjustment greater than 1.000, if applicable, when the defective material is successfully removed and replaced.

Investigate density profile failures and take corrective actions during production and placement to eliminate the segregation. Suspend production if 2 consecutive density profiles fail unless otherwise approved. Resume production after the Engineer approves changes to production or placement methods.

**Table 15**  
**Segregation (Density Profile) Acceptance Criteria**

Mixture Type	Maximum Allowable Density Range (Highest to Lowest)	Maximum Allowable Density Range (Average to Lowest)
Type A & Type B	8.0 pcf	5.0 pcf
Type C, Type D & Type F	6.0 pcf	3.0 pcf

4.9.3.3.3. **Longitudinal Joint Density.**

4.9.3.3.3.1. **Informational Tests.** Perform joint density evaluations while establishing the rolling pattern and verify that the joint density is no more than 3.0 pcf below the density taken at or near the center of the mat. Adjust the

rolling pattern, if needed, to achieve the desired joint density. Perform additional joint density evaluations, at least once per subplot, unless otherwise directed.

- 4.9.3.3.2. **Record Tests.** Perform a joint density evaluation for each subplot at each pavement edge that is or will become a longitudinal joint. Joint density evaluations are not applicable in areas described in Section 341.4.9.3.1.4., "Miscellaneous Areas." Determine the joint density in accordance with [Tex-207-F](#), Part VII. Record the joint density information and submit results on Department forms to the Engineer. The evaluation is considered failing if the joint density is more than 3.0 pcf below the density taken at the core random sample location and the correlated joint density is less than 90.0%. The Engineer will make independent joint density verification at least once per project and may make independent joint density verifications at the random sample locations. The Engineer's joint density test results will be used when available.

Provide the Engineer with the joint density of every subplot in the lot within one working day of the completion of each lot. Report the results of each joint density in accordance with Section 341.4.2., "Reporting and Responsibilities."

Investigate joint density failures and take corrective actions during production and placement to improve the joint density. Suspend production if the evaluations on 2 consecutive sublots fail unless otherwise approved. Resume production after the Engineer approves changes to production or placement methods.

- 4.9.3.3.4. **Recovered Asphalt Dynamic Shear Rheometer (DSR).** The Engineer may take production samples or cores from suspect areas of the project to determine recovered asphalt properties. Asphalt binders with an aging ratio greater than 3.5 do not meet the requirements for recovered asphalt properties and may be deemed defective when tested and evaluated by the Construction Division. The aging ratio is the DSR value of the extracted binder divided by the DSR value of the original unaged binder. Obtain DSR values in accordance with AASHTO T 315 at the specified high temperature performance grade of the asphalt. The Engineer may require removal and replacement of the defective material at the Contractor's expense. The asphalt binder will be recovered for testing from production samples or cores in accordance with [Tex-211-F](#).

- 4.9.3.3.5. **Irregularities.** Identify and correct irregularities including segregation, rutting, raveling, flushing, fat spots, mat slippage, irregular color, irregular texture, roller marks, tears, gouges, streaks, uncoated aggregate particles, or broken aggregate particles. The Engineer may also identify irregularities, and in such cases, the Engineer will promptly notify the Contractor. If the Engineer determines that the irregularity will adversely affect pavement performance, the Engineer may require the Contractor to remove and replace (at the Contractor's expense) areas of the pavement that contain irregularities and areas where the mixture does not bond to the existing pavement.

If irregularities are detected, the Engineer may require the Contractor to immediately suspend operations or may allow the Contractor to continue operations for no more than one day while the Contractor is taking appropriate corrective action.

- 4.9.4. **Exempt Production.** The Engineer may deem the mixture as exempt production for the following conditions:
- anticipated daily production is less than 1,000 tons;
  - total production for the project is less than 5,000 tons;
  - when mutually agreed between the Engineer and the Contractor; or
  - when shown on the plans.

For exempt production, the Contractor is relieved of all production and placement sampling and testing requirements, and the production and placement pay factors are 1.000. All other specification requirements apply, and the Engineer will perform acceptance tests for production and placement listed in Table 14 when 100 tons or more per day are produced.

For exempt production:

- produce, haul, place, and compact the mixture in compliance with the specification and as directed;

- control mixture production to yield a laboratory-molded density that is within  $\pm 1.0\%$  of the target laboratory-molded density as tested by the Engineer;
- compact the mixture in accordance with Section 341.4.8., "Compaction;" and
- when a thermal imaging system is not used, the Engineer may perform segregation (density profiles) and thermal profiles in accordance with the specification.

4.9.5. **Ride Quality.** Measure ride quality in accordance with Item 585, "Ride Quality for Pavement Surfaces," unless otherwise shown on the plans.

---

## 5. MEASUREMENT

1. Hot mix for base repair will be measured by the square yard of composite hot-mix, which includes asphalt, aggregate, and additives. Measure the square yards installed in accordance with the plans provided by the engineer.
2. Hot mix for edge repair will be measured by the linear foot of composite hot-mix, which includes asphalt, aggregate, and additives. Measure the linear feet installed in accordance with the plans provided by the engineer.
3. Hot mix for overlay will be measured by the square yard of composite hot-mix, which includes asphalt, aggregate, and additives. Measure the square yards installed in accordance with the plans provided by the engineer.
4. Hot mix for level up will be measured by the square yard of composite hot-mix, which includes asphalt, aggregate, and additives. Measure the square yards installed in accordance with the plans provided by the engineer.

---

## 6. PAYMENT

The work performed and materials furnished in accordance with this Item and measured as provided under Section 341.5., "Measurement," will be paid for at the unit bid price for "Dense Graded Hot-Mix Asphalt" of the mixture type, SAC, and binder specified. These prices are full compensation for surface preparation, materials including tack coat, placement, equipment, labor, tools, saw-cutting, and incidentals.

Trial batches will not be paid for.

Payment adjustment for ride quality will be determined in accordance with Item 585, "Ride Quality for Pavement Surfaces."